

Five Seasons

OWNER'S MANUAL

MODEL 590AIV

ELECTRONIC AIR CLEANER, IONIZER & VOC FILTER

IMPORTANT: PLEASE READ MANUAL BEFORE OPERATING UNIT

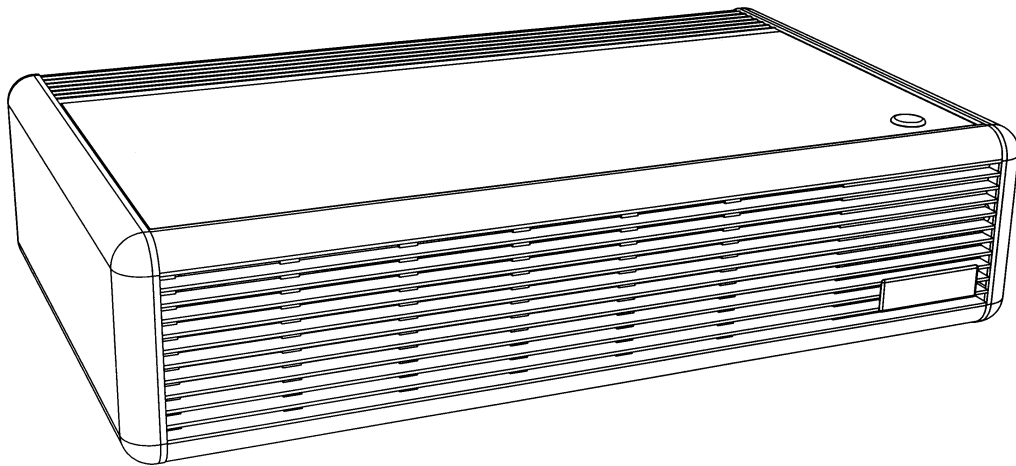

Features

- Lifetime Electronic Filter never needs replacing—simply washes clean
- Electronically removes dust, mites, pollen, pet dander, mold, bacteria, viruses, tobacco smoke, cooking smoke and grease, and more down to 0.01 micron
- Activated Carbon Odor & Gas (VOC) Removal Filter removes Volatile Organic Compounds emitted from common sources within the home and office
- Dual Negative Ionizer restores the air's natural ion balance
- Quiet 3-Speed Fan is comfortable for room occupants
- Performance Indicator Light shows Air Cleaner is operating properly at a glance
- Ideal for rooms up to 320 ft² (29.5 m²) for one room air change every 20 minutes

BENEFITS

- Helps provide relief from allergy, asthma and respiratory illness.
- Helps clear a smokey environment quickly, so everyone can work and relax together.
- Helps reduce the time and money spent cleaning and redecorating. Prevents damaging black dust from staining walls, upholstery and window coverings.
- Helps reduce tobacco, cooking and pet odors.
- Revitalizes the air with healthy negative ions.
- Improves indoor air quality for a fresher, more comfortable environment, year-round.

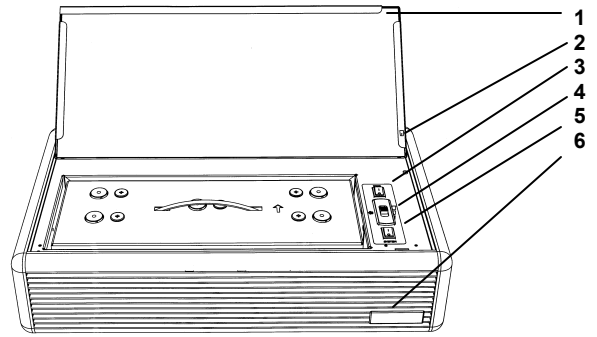

- 1 - Lid which activates Safety Interlock
- 2 - Negative Ion Emitter
- 3 - Negative Ion Control Switch
- 4 - 3-Speed Fan Control Switch
- 5 - System Switch
- 6 - Operation Lights

- The Fan Control Switch in the front position is low speed, the center position is medium, and the rear position is high speed.

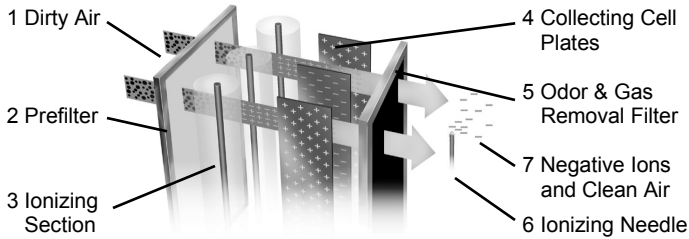

HOW IT WORKS

Dirty air is drawn in through the front grill and passes through a 4-stage filtering system.

The Prefilter consists of aluminum mesh and a close knit polymesh. It prevents larger particles, lint and hair from entering the collecting cell.

The next step is a 2-Stage Electrostatic Collecting Cell. Dirt particles are charged with a high positive voltage by a series of fine ionizing wires. The charged particles are drawn through to the collecting plates where the dirt adheres to the grounded plates, and remains until the cell is taken out and washed. Removes particles down to 0.01 micron (1/2,540,000 of an inch).

The air is then drawn through an Activated Carbon Odor & Gas VOC (Volatile Organic Compound) Removal Filter to help remove offensive odors and gases. Clean air is then discharged out the top of the Air Cleaner.

Dual Negative Ionizer is located in the clean air stream. Adding healthy negative ions to the air revitalizes the air similar to that near a waterfall, spring, the ocean, or after a rainfall. Studies have shown that negative ions have a beneficial effect on human biochemistry, both physically and mentally.

OPERATING INSTRUCTIONS

1. Remove the Air Cleaner from the box and check for apparent damage. If your unit has any signs of damage, immediately contact the store where the Air Cleaner was purchased.
2. Keep the shipping carton in case the need arises to store or transport the unit.
3. Remove all packaging from the unit. Choose a suitable table or stand to allow unobstructed circulation from front and top of unit. The unit performs best when the back is against a wall. This enhances air circulation. To mount unit on wall, refer to the Wall Mount Instructions.
4. Operate Air Cleaner at voltage shown on back of unit.
5. The System Switch controls the power to the Fan Control Switch and the power board. When the System Switch is **ON**, the green light behind the front grill will be illuminated.

Use the low or medium speed for quiet, continuous or nighttime use. Use the high speed for initial cleaning of heavy concentrations of dirty air (i.e. smoke) or after leaving the room.

- The negative ions are controlled by a separate switch located behind the fan control switch. When the switch is **ON**, the red light will be illuminated. **Note: The Negative Ion Emitter will not work without the System Switch being ON.**

- To access the prefilter, collecting cell or activated carbon filter, press firmly on the right front dimple on the lid and release. Lift the lid releasing it from the magnet.

You may notice arcing or snapping from the cell. It is normal to hear some arcing when the unit is new or first turned on. Arcing in the cell may also be caused by high humidity (over 80%), after washing, or when a large particle of dirt or hair is caught in the cell. If the arcing is continuous and constant, then refer to the Troubleshooting Chart.

WALL MOUNT INSTRUCTIONS

- To mount Air Cleaner on wall, remove the rear feet (2) from the bottom of the Air Cleaner, to expose the keyhole slots.
- To remove the feet from the Air Cleaner, you will need a small, flat screwdriver. Pry up the center pin of the rear foot until the head protrudes above the foot. Place the flat portion of the screwdriver under the foot and pry up. This will release the foot from the cabinet. Keep the feet in case you wish to table mount the unit in future.
- Find the location on the wall where you wish to place the Air Cleaner. The unit should be placed 3 feet (1 m) below the ceiling. Use appropriate fasteners for the type of wall the unit will be mounted and insure the head of the screw will fit into the larger opening of the keyhole slot. The screw head should be larger than the smaller opening of the keyhole. The Air Cleaner weighs approximately 20 lbs (9 kg). The distance between the holes in the cabinet bottom is 16 3/4 in (42.5 cm).
- After placing the screws in the wall, adjust the amount of the screw sticking out to approximately 1/8 in (.32 cm). Place the Air Cleaner over the screw head and allow the head to slip into the keyhole slot. Pull the unit down slightly to allow the screw head to slide into the smaller portion of the slot.

CLEANING INSTRUCTIONS

The prefilter and collecting cell must be washed on a regular basis for the Air Cleaner to function at its peak efficiency. The frequency of cleaning will vary from one environment to another, therefore the cell should be checked monthly to determine cleaning schedule. On average, the cell should be washed every 2-3 months.

COLLECTING CELL

1. Turn Air Cleaner **OFF**. Remove the cell from the Air Cleaner. Slide the prefilter and carbon filter out of the retaining brackets before cleaning.
2. Rinse prefilter and cell, and spray completely with DAX Detergent (or non-chlorine, non-corrosive, non-abrasive, non-ammonia liquid household detergent). Let stand for 5 minutes. Rinse well with hot water (120°F / 49°C maximum). Repeat process 3 times.
3. If dirt remains, let cell soak in a solution of DAX Detergent and hot water for 30 minutes.
4. For drying, place the cell on a 45° angle on one end, with the arrow pointing sideways, and let stand for 10-24 hours. A hair dryer may be used to speed up drying time. Make sure the cell is completely dry before reinserting back into Air Cleaner. The arrow on the cell must point toward the fan blower.
5. If arcing or snapping occurs or the lights do not come on when the cell is placed back in the unit and turned on, then remove the cell and allow to dry longer.

ODOR & GAS (VOC) REMOVAL FILTER

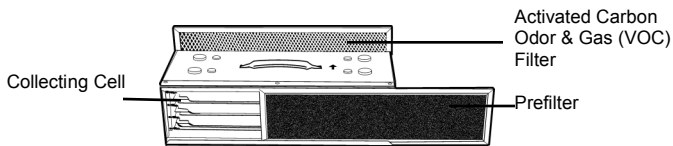

1. The Activated Carbon Odor & Gas (VOC) Removal Filter must be replaced at regular intervals if odor removal is desired (approximately every 3-6 months). **ODOR REMOVAL FILTERS ARE NOT WASHABLE.**

CABINET

1. Turn Air Cleaner **OFF**.
2. A soft, damp, lint-free cloth may be used to remove dirt and fingerprints from painted surfaces, grills and end panels. **NEVER USE AN ABRASIVE CLEANER ON THE CABINET.**

WARNING

- **DO NOT WASH COLLECTING CELL IN DISHWASHER.**
- Never use any object to clean between the cell plates as this may cause damage to the plates or ionizing wires.
- Never place the cell in an oven to dry.
- The edges of the cell may be sharp — handle with care.

DAX Detergent, No. 9900, and the Activated Carbon Odor & Gas (VOC) Removal Filter, No. 59-0810, are available from your retail outlet.



TROUBLESHOOTING CHART

PROBLEM	CAUSE
Fan does not operate Both Operation Lights off	<ul style="list-style-type: none"> • Unit not plugged in • System switch not ON • Fan switch not in proper position • Lid not securely closed
Green Performance Light on Red Ion Light off	<ul style="list-style-type: none"> • Negative Ion switch not in ON position
Fan operating Both Operation Lights off	<ul style="list-style-type: none"> • Cell wet from washing • Short in cell (see below)
Cell arcing excessively	<ul style="list-style-type: none"> • Cell wet from washing • Cell plate(s) bent • Cell dirty or large lint ball/hair caught in cell • Broken ionizing wire(s) • Prefilter is in backward (black mesh should be visible on outside)
Air Cleaner vibrating excessively	<ul style="list-style-type: none"> • Unit not sitting on flat surface
Both Operation Lights on Cell not collecting dirt	<ul style="list-style-type: none"> • Cell is in backward (Arrow on cell should point towards fan blower)

The two Operation Lights, located behind the front grill, are also used as the high voltage fault indicator. If the fan is operating, but the lights do not come on, then there is a problem in the high voltage circuit. To determine what the problem is, turn the Air Cleaner **OFF** and remove the collecting cell. Close the lid and turn the Air Cleaner back **ON**. If the lights come back on, the problem lies in the cell. Check the cell for wetness from washing or look for a broken ionizing wire(s) or bent cell plate(s).

If the lights do not come on, the problem is with the power board or Operation Light(s). If you are unable to correct any of the above problems, call 1-800-267-8305.

TECHNICAL DATA

Dimensions	Width	20.0 in	50.8 cm
	Depth	12.0 in	30.5 cm
	Height	5.0 in	12.7 cm
Weight		16.0 lbs	7.3 kg
Input Voltage	120 V	60 Hz	220 V 60 Hz
	220 V	50 Hz	220-240 V 50 Hz
Power Consumption (maximum)		85 Watts	
Air Flow	High	130 cfm	221 m ³ /hr
	Medium	80 cfm	136 m ³ /hr
	Low	60 cfm	102 m ³ /hr
Cell Output Voltage		6500 VDC @ < 1 mA	
Collecting Cell Surface		756 in ²	4877 cm ²
Negative Ionizer		-5000 VDC @ <.1 mA	
Negative Ion Output		2 x 327.7 K/in ³	2 x 20 K/cm ³
Ideal for rooms up to: (1 room air change every 20 minutes for maximum room size)		320 ft ²	29.5 m ²



IMPORTANT SAFEGUARDS

Safety points you should know about your Electronic Air Cleaner and Ionizer.

Caution:

**** Read Owner's Manual and safeguards before using**

**** Save Owner's Manual for later use**

**** Follow all warnings and instructions marked on Air Cleaner**

FOR YOUR PERSONAL SAFETY

1. The Air Cleaner is equipped with a grounded plug. Do not defeat the purpose of this plug by removing the grounding pin, as this may result in an electrical shock or create an unsafe condition.
2. When the power cord or plug is damaged or frayed, unplug the Air Cleaner from the wall outlet and refer servicing to qualified service personnel.
3. Do not overload wall outlets and extension cords, as this can result in fire or electric shock.
4. Do not allow anything to rest on or roll over the power cord, and do not place the unit where power cord is subject to traffic or abuse. This may result in a shock or fire hazard.
5. Do not attempt to service the Air Cleaner yourself as opening or removing switch cover may expose you to dangerous voltage or other hazards. Refer all servicing to qualified personnel.
6. Never push objects of any kind into the Air Cleaner through cabinet slots, as they may touch dangerous voltage points, or short out parts that could result in a fire or electric shock.
7. If the Air Cleaner has been dropped or the cabinet has been damaged, unplug the unit from the wall outlet and refer servicing to qualified service personnel.
8. Unplug the Air Cleaner from the wall outlet before cleaning. Do not use liquid cleaners or aerosol cleaners on cabinet. Use a damp, lint-free cloth for cleaning, except when cleaning the cell.
9. Do not use the Air Cleaner near water, i.e. near a bathtub, sink, laundry tub, in a wet basement, in the rain or near a swimming pool, etc.
10. Do not use the Air Cleaner near open fire or flame, or sources of heat i.e. fireplaces, wood burning stoves, kerosene heaters, stove tops, ovens, etc.
11. Do not use the Air Cleaner on soft surfaces i.e. beds, sofas.
12. Do not use the Air Cleaner when oxygen is being used or when combustible gases are present.
13. The Air Cleaner has slots or openings in the cabinet for ventilation purposes, to provide reliable operation of the unit, and to protect it from overheating. These openings must not be blocked or covered.
14. The Air Cleaner should be operated only from the type of power source indicated on the rating label. If you are not sure of the type of power supply at your home, consult your local power company.
15. It is normal for the Air Cleaner to make occasional snapping or popping sounds, particularly when being turned on after washing. If the snapping or popping is continuous or frequent, unplug the unit and call 1-800-267-8305.
16. If the Air Cleaner does not operate normally by following the operating instructions, unplug the unit from the wall outlet and refer servicing to qualified service personnel.

LIMITED ONE YEAR WARRANTY

Your Electronic Air Cleaner is guaranteed for one (1) full year from the date of original purchase, against electrical and mechanical defects in material and workmanship, under normal use and maintenance, which will be repaired or replaced without charge, upon inspection by an authorized service center. The warranty does not include the Prefilter or Carbon Filter.

This guarantee is in lieu of any other warranty, either expressed or implied.

FIVE SEASONS COMFORT LIMITED will not be responsible for:

1. Normal maintenance including cleaning or replacement of filters, as outlined in the Owner's Manual.
2. Damage or repairs needed as a consequence of any misuse, negligent handling, improper servicing, unauthorized alteration, improper operations or use on voltage other than that stamped on the Air Cleaner.
3. Any personal injury, property damage, or any incidental or consequential damages of any kind, resulting from defects, malfunctions, misuse, or alteration of the product.
4. Damage as a result of floods, winds, fires, lightning, accidents, corrosive atmosphere, or other conditions beyond the control of Five Seasons Comfort Limited.
5. Parts, including filters not supplied or designated by Five Seasons Comfort Limited.

If warranty service is required, send the Air Cleaner **prepaid** to your dealer or nearest authorized service center, with a **proof of purchase**. The original carton and packaging must be used. If not, and if goods arrive damaged due to improper packaging, warranty will be void. Please enclose a note explaining the nature of your difficulty.

FIVE SEASONS COMFORT LIMITED

351 North Rivermede Road, Concord, Ontario, Canada L4K 3N2

Tel: (416) 213-5636 Fax: (416) 213-5593

Toll Free: 1-800-267-8305

info@fiveseasonsaircleaners.com www.fiveseasonsaircleaners.com